



**ASHOK LEYLAND**

ENGINEERING YOUR TOMORROWS

# U-TRUCK

**U-2518 T**

**6X4 TIPPER**



HIGHER FUEL EFFICIENCY  
HIGHER DURABILITY  
3-YEAR PACKAGE



HINDUJA GROUP



## AGGREGATES



### ENGINE

- Turbocharged intercooled 'H' series BSIII diesel engine delivering 180 HP @ 2400 rpm
- Higher torque of 660 Nm @ 1600 – 1800 rpm for better pickup
- Proven 'H' series engine for lower maintenance and longer life



### CLUTCH

- 380 mm dia axial spring clutch with organic lining for longer life
- Clutch booster for fatigueless driving



### GEARBOX

- 6-speed synchromesh gearbox
- First gear ratio of 8.51:1 for operation in all terrains



### REAR AXLE

- Fully-floating single-speed MT-148 hypoid axle for longer life
- Optimised rear axle ratio of 6.5:1 for faster trips and higher fuel efficiency



### FRONT AXLE

- All-new, heavy-duty front axle
- Higher wheel-lock angle for shorter turning-circle dia

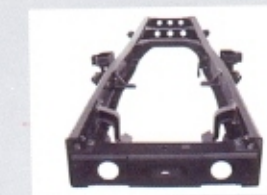

### FRAME

- 11" deep joggled frame with 8 mm thickness to carry heavier payloads
- Flanged fasteners for lesser maintenance



THE U-2518 T IS DESIGNED TO BRING PROFITS FLOWING IN. POWERED BY A FUEL-EFFICIENT 'H' SERIES ENGINE AND MATCHING DRIVELINE, AND SUPPLEMENTED BY A DURABLE BODY AND HYDRAULICS, THE U-2518 T IS SPECIALLY ENGINEERED TO HANDLE ALL THE CHALLENGES OF SURFACE TRANSPORT AND IRRIGATION SITES, MAKING IT IDEAL FOR ALL CONSTRUCTION-RELATED APPLICATIONS.





#### FUEL TANK

- 200 L cross-linked polymer tank
- No formation of rust; higher impact strength
- Reed-type sensor for higher accuracy in measurement of fuel level



#### SUSPENSION

- Front: Semi-elliptic, multi-leaf, uprated springs with shock absorbers for better driving comfort
- Rear: Heavy-duty bogie suspension for higher load-carrying capacity in highly articulated conditions



#### CABIN

- Factory-built day cab
- Fully-suspended cab for better riding comfort
- Spacious cab with larger stowage space
- Retractable seat belt for driver safety
- 3-piece metal bumper with twin headlamps



#### LOAD BODY

- Ashok Leyland hydraulics with in-house service support
- Increased sheet thickness
- Sturdy under-body construction with increased number of cross bearers
- Increased cylinder dia
- High-strength BSK 46 material for body and sub-frame
- Front-end tipping



#### OTHER SALIENT FEATURES

- EDC system for optimal fuel delivery at varying operating conditions
- Long-life air filters
- 6" and 7" brake system in front and rear respectively, with RAF 7 asbestos-free lining for longer life
- Water-proof connectors for all electrical connections
- Push-to-fit connectors to prevent air-pressure drop
- Lamp in the engine compartment
- Sleeping provision in day cab for driver comfort

#### OPTIONAL

- Music system (FM / AM / CD player)
- ALERT (Telematics)



#### SUPERIOR OWNERSHIP EXPERIENCE

2 years / 5000 hours standard warranty

	GOLD	SILVER	BRONZE
Comprehensive maintenance covering all charges for labour, consumables, wear & tear components and lubes	✓		
Scheduled maintenance covering all charges for labour	✓	✓	
Cashless accident repair with assured restoration time	✓	✓	✓
Personal accident cover for the driver	✓	✓	✓

Silver care package with scheduled maintenance covering all charges for consumables and lubes also available.



## TIPPER BODY OPTIONS AND APPLICATIONS

Body	Sheet Thickness (Floor x Side Board x Head Board) mm	Applications
14 cu. m box	6 x 5 x 5	Construction - Sand and blue metal
14 cu. m scow	6 x 5 x 5	Earthwork

## TECHNICAL SPECIFICATIONS

Engine	'H' series BSIII
Maximum power	180 HP @ 2400 rpm
Maximum torque	660 Nm @ 1600 - 1800 rpm
Clutch	15" dia RDC with organic facing material
Transmission	6-speed with 8.51:1 FGR
Front axle	Forged I section reverse Elliot
Rear axle	Fully-floating single-speed hypoid with 6.5:1 RAR
Frame	279 x 90 x 8 joggled bolted frame with 6 cross members
Suspension	Front: Semi-elliptic, multi-leaf Rear: Bogie
Brakes	Full-air, dual-line brakes
Parking brakes	Flick-valve operated pneumatic on rear wheels only
Fuel tank capacity	200 L cross-linked polymer tank
Battery	(12 V 130 AH) x 2
Tyres	10 x 20 - 16 PR

## MAJOR DIMENSIONS (IN MM)

Wheel base	3900
Overall length	7344
Overall width	2504
Front overhang	1520
Rear overhang	1450
Front track	2054
Rear track	1816
Min. ground clearance	260
Min. turning-circle dia	15200

## PERFORMANCE

Maximum speed in top gear	74 kmph
Maximum gradeability	25.4%

## WEIGHT (KGS)

	Unladen (14 cu. m box)	Laden
Front axle	3900	6000
Rear axle	5400	19000
Total	9300	25000

Specifications are subject to change due to continuous improvements and are for reference only.  
Do not drill or weld on the frame.

## COACH BUILDER DRAWING

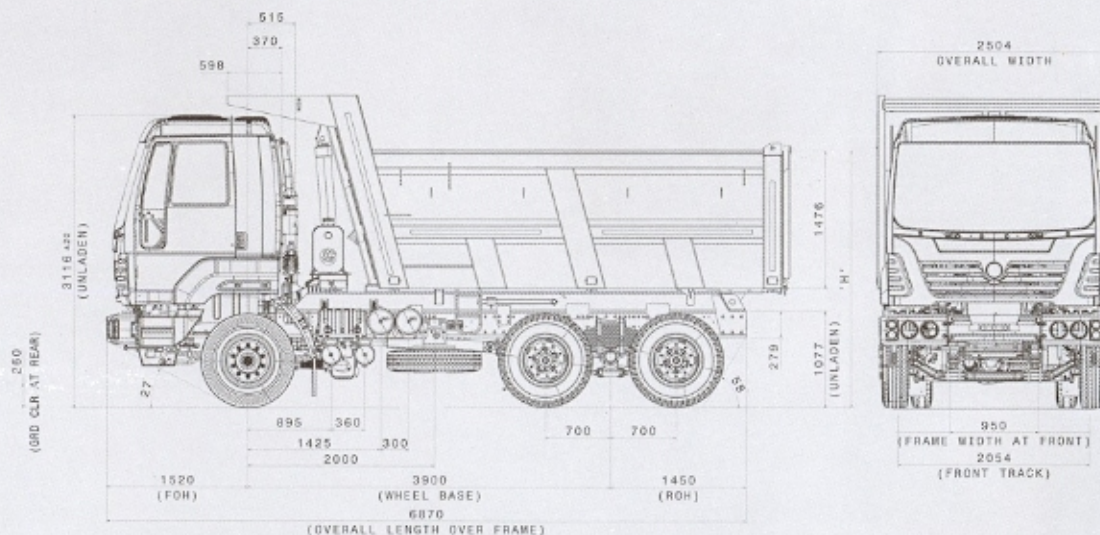

Assured Emergency Response



24 x 7 National Helpline



**ASHOK LEYLAND**  
ENGINEERING YOUR TOMORROWS

**KIFARU**  
**MOTORS ZW**

Tel: +263 774 971 990

Email: admin@kifarumotors.co.zw

No.1, Sardar Patel Road, Guindy, Chennai - 600 032. P: [044] 2220 6000 F: [044] 2220 6001 W: www.ashokleyland.com



HINDUJA GROUP